

Process Interface Valves

Double Block and Bleed (DBB) Valves



Process Interface Valves and Process Monoflanges

- Stainless steel, carbon steel, and duplex stainless steel materials
 - Alloy 2507, Alloy 400, Alloy 625, Alloy 825, 6-Moly, and additional materials may be available upon request
- Pressure ratings in accordance with ASME B16.5 and ASME B16.34 for select configurations
- Flanged connections compatible with ASME B16.5
- Ball valve bore sizes from 3/8 to 2 in. (9.5 to 49 mm)
- Low emissions options per API 641, API 624, ISO 15848-1

Contents

Process Interface Valves

- Markets 3
- Applications 3
- Installation Advantages 3
- Custom Configurations 3

Features

- Testing 4
- Sour Gas Service 4
- Sizes and Configurations 4
- Design and Performance Specifications 4

Flange Connections

- Pressure-Temperature Ratings 5
- Dimensions 5

Double Block and Bleed DBB

- Features 6

VS03 Series



- Materials of Construction 7
- Pressure-Temperature Ratings 7
- Dimensions 8
- Ordering Information 10
- Available Options 10

VB04 Series



- Materials of Construction 11
- Pressure-Temperature Ratings 11
- Dimensions 12
- Ordering Information 14
- Options 16
- Available Options 17

VS04 Series



- Materials of Construction 18
- Pressure-Temperature Ratings 18
- Dimensions 19
- Ordering Information 22
- Available Options 23

Process Monoflanges

MS Series



- Features 24
- Materials of Construction 24
- Pressure-Temperature Ratings 24
- Duplex Elevated Temperature Rating 24
- Configurations 25
- Dimensions 26
- Ordering Information 28
- Available Options 29

Accessories

- Accessories 30

Process Interface Valves

Swagelok® process interface valves enable a smooth transition from the process piping system to instrumentation in a single configuration, providing fewer potential leak points, lower installed weight, and a smaller space envelope.

Markets

- Oil and gas
- Chemical and refining
- Power generation

Applications

- Process piping isolation points
- Direct mount to instruments
- Close coupling of instruments
- Chemical injection and sampling points
- Double block and bleed isolation
- Vents and drains
- Extreme service

Oil and Gas



© Mark Karrass/Corbis.

Chemical and Refining



Power Generation



Over 100 000 double block and bleed and monoflange valves installed.

Installation Advantages

- Fewer leak points
- Smaller compact design
- Weight reduction of up to 75%
- Reduced installation time
- Reduced vibration stress
- Reduced fugitive emissions
- Low emission options per API 641, API 624, ISO 15848-1
- Integral Swagelok® tube fitting (connection options)

Low Fugitive Emissions

The American Petroleum Institute's API 641, API 624 and the International Organization for Standardization ISO 15848-1 test for fugitive emissions to atmosphere for quarter-turn ball valves and rising stem valves. For more information, contact your authorized Swagelok sales and service representative.

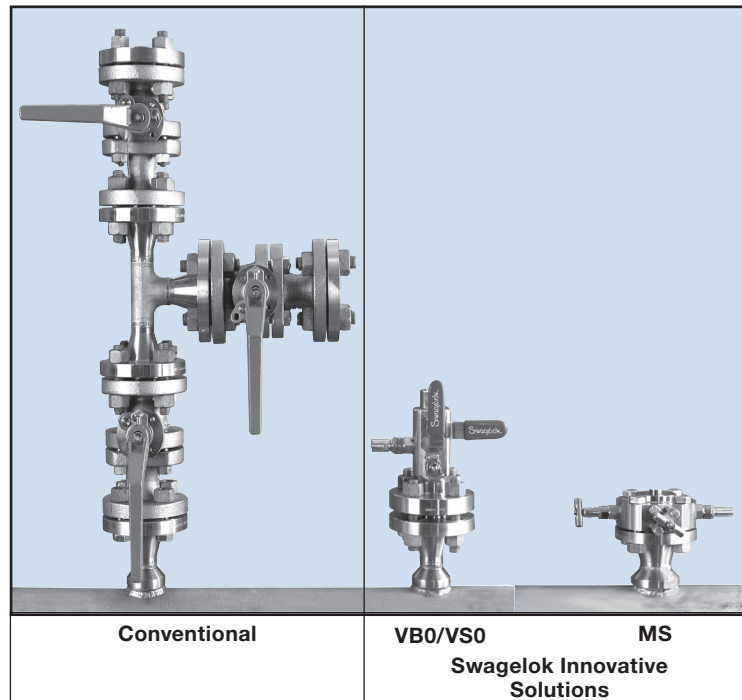

Custom Configurations

Swagelok process interface valves and process monoflanges can be configured to suit a variety of special applications. In addition to double block and bleed assemblies, single block and bleed, and block combinations are available. Block and bleed globe valve module options are also available. Contact your authorized Swagelok sales and service representative for assistance with any special requirements.

Features

Testing

Every process interface valve is factory tested hydrostatically to a requirement of no visible leakage. A shell test is performed at 1.5 times maximum rated working pressure and a seat test is performed at 1.1 times maximum rated working pressure, in accordance with BS EN 12266-1 and API 598. A low-pressure gas seat test is performed in accordance with BS EN 12266-1 and API 598.

Sour Gas Service

Process interface valves for sour gas service are available. Materials listed are selected in accordance with NACE MR0175/ISO 15156.

Sizes and Configurations

	VS03	VB04	VS04	MS
	3 Piece	Integral	Integral	Monoflange
Bore Size, in. (mm)				
2 (50)	✓			
1 1/2 (38)	✓			
1 (25)	✓			
3/4 (20)		✓		
1/2 (14)		✓		
3/8 (9.5)			✓	
0.2 (5)				✓
Valve Configuration				
Double Block Bleed	✓	✓	✓	✓
Single Block Bleed	✓	✓	✓	✓
Single Block		✓	✓	✓
End Configuration				
Flange x Flange	✓	✓	✓	
Flange x Thread		✓ ^①	✓ ^①	✓
Thread x Thread		✓ ^①	✓ ^①	

① Swagelok tube fitting end connections are available as an option instead of threads.

Design and Performance Specifications

	VS03	VB04	VS04	MS
	3 Piece	Integral	Integral	Monoflange
Pressure Temperature and Wall Thickness				
ASME B16.5 Flanges	✓	✓	✓	✓ ^①
ASME B1.20.1 NPT Threads	✓	✓	✓	✓
ASME B31.3 Process Piping	✓	✓	✓	✓
Shell and Seat Testing				
BS EN 12266-1 and API 598	✓	✓	✓	✓
Shell and Seat Test per API 6D	✓	✓	✓	✓
Antiblowout Stem and Needles				
EEMUA-182	✓	✓	✓	
Self-Relieving Ball Valve Cavity				
EEMUA-182	✓	✓	✓	
Fire Safe Design				
Fire Safe Design	✓	✓	✓	✓ ^③
API 607 Certification	✓		✓	✓
BS 6755-2, Third Party Fire Certification		✓ ^②		
Antistatic Design				
ISO 17292	✓	✓	✓	✓
Low Emissions				
API 641		✓		
API 624		✓ ^②		
ISO 15848-1	✓		✓	✓

① ASME B16.5 compatible

② Available on select configurations

③ OS&Y design with Graphite only

Flange Connections

Pressure-Temperature Ratings

Swagelok process interface valves carry the pressure-temperature ratings of their flange end connections, which meet ASME B16.5 dimensional specifications and pressure ratings in a range of flange sizes and pressure classes.

316/316L Working Pressure by Class, psig

Temperature °F	ASME Class					
	150	300	600	900	1500	2500
	Working Pressure, psig					
-20 to 100	275	720	1440	2160	3600	6000
200	235	620	1240	1860	3095	5160
300	215	560	1120	1680	2795	4660
400	195	515	1025	1540	2570	4280
500	170	480	955	1435	2390	3980
600	140	450	900	1355	2255	3760
650	125	440	885	1325	2210	3680
700	110	435	870	1305	2170	3620
750	95	425	855	1280	2135	3560
800	80	420	845	1265	2110	3520
850	65	420	835	1255	2090	3480

Ratings shown below are for 316/316L dual-certified stainless steel, see ASME B16.5-2020 tables 2-2.2 and F2-2.2. For valve working temperature ratings, see series' specific information.

316/316L Working Pressure by Class, bar

Temperature °C	ASME Class					
	150	300	600	900	1500	2500
	Working Pressure, bar					
-29 to 38	19.0	49.6	99.3	148.9	248.2	413.7
50	18.4	48.1	96.2	144.3	240.6	400.9
100	16.2	42.2	84.4	126.6	211.0	351.6
150	14.8	38.5	77.0	115.5	192.5	320.8
200	13.7	35.7	71.3	107.0	178.3	297.2
250	12.1	33.4	66.8	100.1	166.9	278.1
300	10.2	31.6	63.2	94.9	158.1	263.5
325	9.3	30.9	61.8	92.7	154.4	257.4
350	8.4	30.3	60.7	91.0	151.6	252.7
375	7.4	29.9	59.8	89.6	149.4	249.0
400	6.5	29.4	58.9	88.3	147.2	245.3
425	5.5	29.1	58.3	87.4	145.7	242.9
450	4.6	28.8	57.7	86.5	144.2	240.4

Dimensions

Dimensions are for reference only and are subject to change.

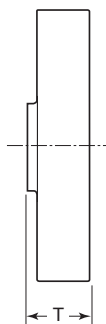
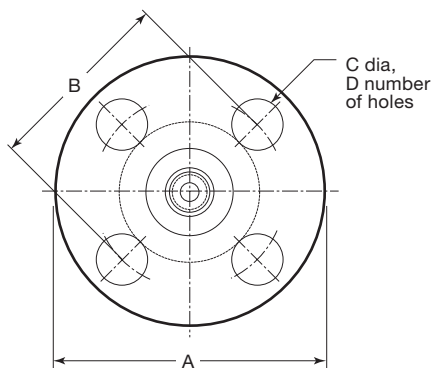

See each series for T dimension.

Class 150

Nominal Flange Size in.	Dimensions in. (mm)			Mounting Holes D
	A	B	C	
1/2	3.50 (88.9)	2.38 (60.5)	0.62 (15.7)	4
3/4	3.88 (98.6)	2.75 (69.8)	0.62 (15.7)	
1	4.25 (108)	3.12 (79.2)	0.62 (15.7)	
1 1/2	5.00 (127)	3.88 (98.6)	0.62 (15.7)	
2	6.00 (152)	4.75 (121)	0.75 (19.0)	
3	7.50 (190)	6.00 (152)	0.75 (19.0)	

Class 300/Class 600

Nominal Flange Size in.	Dimensions in. (mm)			Mounting Holes D
	A	B	C	
1/2	3.75 (95.2)	2.62 (66.5)	0.62 (15.7)	4
3/4	4.62 (117)	3.25 (82.6)	0.75 (19.0)	
1	4.88 (124)	3.50 (88.9)	0.75 (19.0)	
1 1/2	6.12 (155)	4.50 (114)	0.88 (22.4)	8
2	6.50 (165)	5.00 (127)	0.75 (19.0)	
3	8.25 (210)	6.62 (168)	0.88 (22.4)	

Class 900/Class 1500

Nominal Flange Size in.	Dimensions in. (mm)			Mounting Holes D
	A	B	C	
1/2	4.75 (121)	3.25 (82.6)	0.88 (22.4)	4
3/4	5.12 (130)	3.50 (88.9)	0.88 (22.4)	
1	5.88 (149)	4.00 (102)	1.00 (25.4)	
1 1/2	7.00 (178)	4.88 (124)	1.13 (28.7)	
2	8.50 (216)	6.50 (165)	1.00 (25.4)	8
3 (cl 900)	9.50 (241)	7.50 (190)	1.00 (25.4)	
3 (cl 1500)	10.5 (267)	8.00 (203)	1.25 (31.8)	

Class 2500

Nominal Flange Size in.	Dimensions in. (mm)			Mounting Holes D
	A	B	C	
1/2	5.25 (134)	3.50 (88.9)	0.88 (22.4)	4
3/4	5.50 (140)	3.75 (95.2)	0.88 (22.4)	
1	6.25 (159)	4.25 (108)	1.00 (25.4)	
1 1/2	8.00 (203)	5.75 (146)	1.25 (31.8)	
2	9.25 (235)	6.75 (171)	1.13 (28.7)	8

Double Block and Bleed (DBB)

Swagelok process interface valves provide a smooth transition from process to instrumentation systems in a single, compact assembly. Benefits include fewer leak points and reduced size and weight compared to traditional systems.

Features

- Valves and fittings use materials selected in accordance with NACE MR0175/ISO 15156
- Some materials offered are compliant with NORSOK M650
- Process interface in one compact ball/needle/ball valve assembly. Three-piece, bolted-body (VS03 series) or one-piece forged body (VB04 and VS04 series) construction
- All VS03 and VS04 series valves are compliant to ASME B16.34
- Flange connections compatible with ASME B16.5; NPT connections compatible with ASME B1.20.1
- Antiblowout valve stems and needles
- Nonrotating needle vent valve
- Self-relieving ball cavity
- Firesafe design
- Antistatic design
- Low emissions
 - VS03 only — certified per ISO 15848-1 standard
 - VS04 and MS0 — certified per ISO 15848-1 option available
- Hydrostatic test certificates available per ISO 15156 (3.1)
- Chemical and physical material certifications available
- Dye penetrant and magnetic particle examination available
- Every process interface valve is tested hydrostatically to a requirement in accordance with API 598 and BS EN 12266-1

VB04 Series
(14 mm and 20 mm bore)

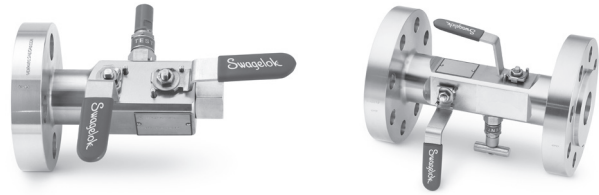

VS03 Series

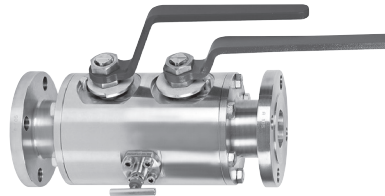

VS04 Series
(9.5 mm bore)

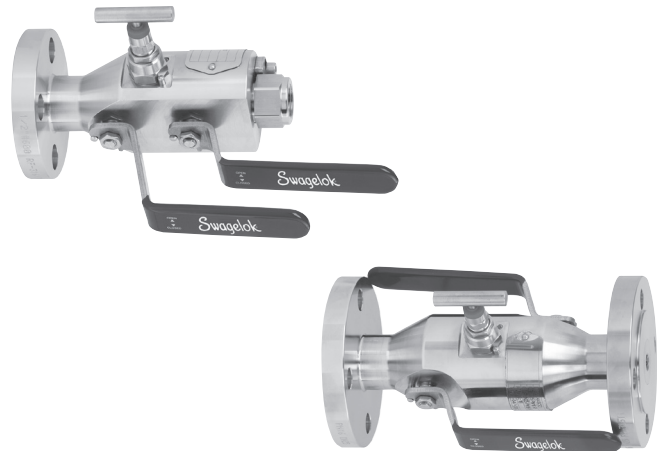

Swagelok Tube Fittings Can Be Integrated Directly Into Double Block and Bleed and Monoflanges

How We Outperform

Swagelok tube fittings have a grip-type design that uses a unique “hinging and colletting” action to achieve optimal performance in three key areas:

- Tube grip—hinging and colletting action provides more direct tube contact/gripping support
- Gas seal—burnishing/polishing action of the front ferrule creates concentrated zones of contact on the tube and on the body bevel for a stronger seal
- Vibration resistance—the colletting region better isolates stress risers at the tube grip to resist bending, deflection, and vibration

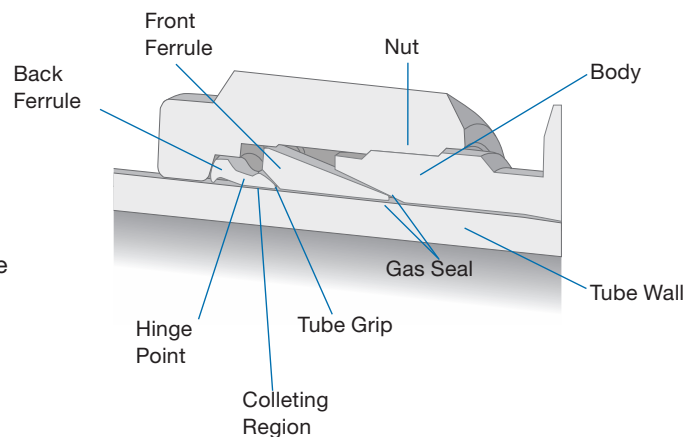

VS03 Series

Materials of Construction

Component	Valve Body Materials		
	Stainless Steel	Carbon Steel	Duplex Stainless Steel
	Material Grade/ASTM Specification		
<i>Body</i>	316/316L SS /A479	Carbon steel/ A350 LF2 class 2 ^②	S31803/ A479 S31803
<i>Ball valve end connections</i>	316/316L SS /A479		S31803 /A479 ^③
<i>Ball valve stems</i>	316/316L SS/A479 ^④		S31803/A479
<i>Ball valve seats</i>	PEEK		
<i>Ball valve stem seal</i>	Graphite		
<i>O-rings</i>	FKM		
<i>Needle</i>	S17400 SS/A564 condition H1150D ^⑤		
<i>Body seals, needle valve packing</i>	Graphite		
Body bolts	B8M/A193, class 2 8M/A194	L7M/A320 ^⑤ 7M/A194 ^⑤	
All other components	316 SS		

Wetted components listed in *italics*.

- ① Certain configurations may use XM19 H1150. Contact your authorized Swagelok sales and service center for more information.
- ② Carbon steel is treated with rust inhibitor.
- ③ Optional Swagelok end connections are only available in super duplex stainless steel.
- ④ Alternative needle materials are available.
- ⑤ Bolts are hot-dipped galvanized.

- ⚠ A packing adjustment may be required periodically to increase service life and to prevent leakage.
- ⚠ Valves that have not been cycled for a period of time may have a higher initial actuation torque.
- ⚠ To increase service life, ensure proper valve performance, and prevent leakage, apply only as much torque as is required to achieve positive shutoff.

Pressure-Temperature Ratings

Pressure Rating

Class 150 to class 2500 in accordance with ASME B16.5; see page 5.

Valve Working Temperatures

- -20° to 356°F (-29° to 180°C) for FKM 90VAA5800 O-rings
- -50° to 248°F (-46 to 120°C) for FKM 90VAB5800 low-temperature O-rings

VS03 Series

Dimensions

Dimensions are for reference only and are subject to change.

For additional flange dimensions, see page 5.

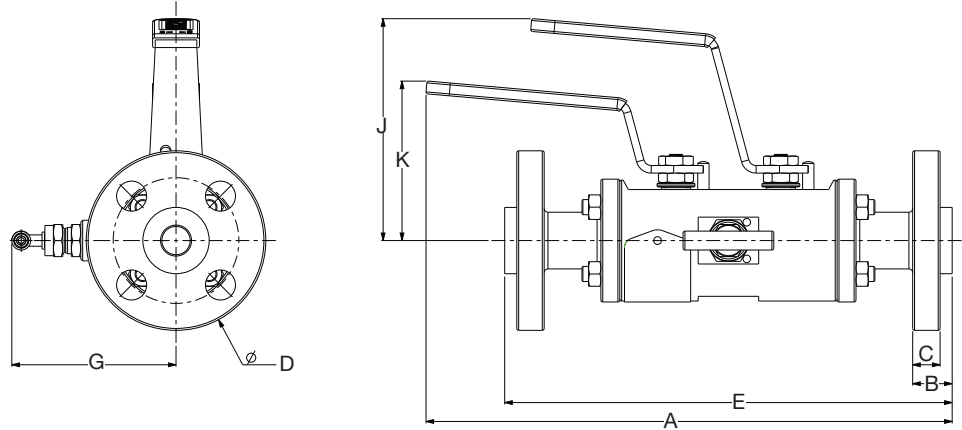

Full Bore (based on RF Flanges)

Flange Size/Full-Bore Size in.	Reduced-Bore Option in. (mm)	ASME Class	Dimensions, in. (mm)								Weight lb (kg)
			A	B	C	Ø D	E	G	J	K	
1 (DN 25)	—	150	17.0 (431)	0.60 (14.5)	0.50 (13.0)	4.30 (108)	11.0 (279)	4.50 (114)	5.60 (143)	4.00 (102)	26.5 (12)
		300	17.5 (445)	0.80 (19.0)	0.70 (17.5)	4.90 (124)	11.7 (297)	4.50 (114)	5.60 (143)	4.00 (102)	28.7 (13)
		600	17.5 (445)	0.90 (24.0)	0.70 (17.5)	4.90 (124)	12.1 (307)	4.50 (114)	5.60 (143)	4.00 (102)	30.9 (14)
		900/1500	19.7 (501)	1.40 (35.0)	1.10 (28.5)	5.90 (149)	16.5 (419)	4.80 (122)	5.70 (145)	4.40 (112)	61.7 (28)
		2500	20.0 (508)	1.70 (42.0)	1.40 (35.5)	6.30 (159)	17.0 (433)	4.80 (122)	5.70 (145)	4.40 (112)	66.1 (30)
1 1/2 (DN 40)	1 (25.4)	150	18.5 (470)	0.70 (17.5)	0.60 (16.0)	5.00 (127)	12.8 (326)	4.90 (125)	6.10 (155)	4.50 (114)	44.1 (20)
		300	19.3 (490)	1.00 (25.0)	0.90 (22.5)	6.10 (155)	14.1 (356)	4.90 (125)	6.10 (155)	4.50 (114)	48.5 (22)
		600	19.3 (490)	1.20 (30.0)	0.90 (22.5)	6.10 (155)	14.4 (366)	4.90 (125)	6.10 (155)	4.50 (114)	55.1 (25)
		900/1500	32.4 (822)	1.50 (38.5)	1.30 (32.0)	7.00 (178)	20.7 (527)	6.40 (162)	7.80 (199)	5.90 (150)	187 (85)
		2500	33.0 (838)	2.00 (51.0)	1.80 (44.5)	8.00 (203)	22.0 (559)	6.40 (162)	7.80 (199)	5.90 (150)	209 (95)
2 (DN 50)	1 1/2 (38.1)	150	20.2 (512)	0.70 (19.0)	0.70 (17.5)	6.00 (152)	14.3 (364)	5.60 (142)	7.20 (182)	5.40 (138)	77.2 (35)
		300	20.6 (524)	1.10 (27.0)	1.00 (25.5)	6.50 (165)	14.9 (378)	5.60 (142)	7.20 (182)	5.40 (138)	81.6 (37)
		600	20.6 (524)	1.30 (32.0)	1.00 (25.5)	6.50 (165)	15.3 (388)	5.60 (142)	7.20 (182)	5.40 (138)	88.2 (40)
		900/1500	27.0 (687)	1.80 (44.5)	1.50 (38.5)	8.50 (216)	18.6 (472)	5.60 (142)	7.20 (184)	5.40 (138)	137 (62)
		2500	37.0 (939)	2.30 (57.5)	2.00 (51.0)	9.30 (235)	22.8 (579)	6.50 (166)	6.90 (175)	9.70 (247)	264 (120)
3 (DN 80) Reduced bore only	2 (50.8)	150	20.4 (517)	0.90 (23.9)	0.90 (22.4)	7.50 (190)	14.7 (374)	5.50 (140)	7.20 (182)	5.40 (138)	90.4 (41)
		300	20.7 (525)	1.10 (28.4)	1.10 (26.9)	8.30 (210)	15.3 (390)	5.50 (140)	7.20 (182)	5.40 (138)	99.2 (45)
		600	21.1 (535)	1.50 (38.2)	1.30 (31.8)	8.30 (210)	16.1 (410)	5.50 (140)	7.20 (182)	5.40 (138)	99.2 (45)
		900	27.0 (687)	1.80 (44.5)	1.50 (38.1)	9.50 (241)	18.6 (472)	5.50 (140)	9.10 (230)	7.20 (184)	150 (68)
		1500	27.8 (705)	2.10 (54.2)	1.90 (47.8)	10.5 (267)	20.0 (508)	5.50 (140)	9.10 (230)	7.20 (184)	183 (83)
		2500	37.9 (963)	2.90 (72.9)	2.60 (66.5)	12.0 (305)	24.7 (627)	6.40 (163)	9.10 (230)	8.30 (210)	357 (162)

VS03 Series

Dimensions

Dimensions are for reference only and are subject to change.

For additional flange dimensions, see page 5.

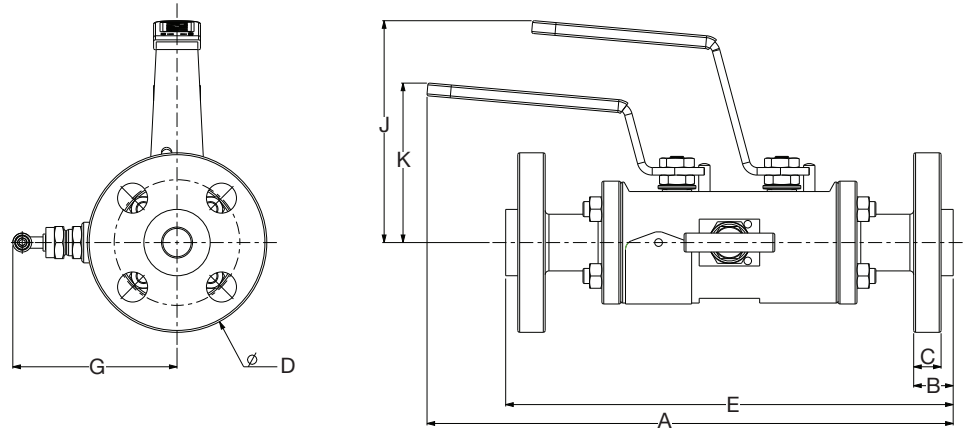

Full Bore (based on RJ Flanges)

Flange Size/Full-Bore Size in.	Reduced-Bore Option in. (mm)	ASME Class	Dimensions, in. (mm)								Weight lb (kg)
			A	B	C	Ø D	E	G	J	K	
1 (DN 25)	—	150	17.0 (431)	0.80 (19.5)	0.50 (13.0)	4.30 (108)	11.4 (289)	4.50 (114)	5.60 (143)	4.00 (102)	28.7 (13)
		300/600	17.5 (445)	0.90 (24.0)	0.70 (17.5)	4.90 (124)	12.1 (307)	4.50 (114)	5.60 (143)	4.00 (102)	30.9 (14)
		900/1500	19.7 (501)	1.40 (35.0)	1.10 (28.5)	5.90 (149)	16.5 (419)	4.80 (122)	5.70 (145)	4.40 (112)	61.7 (28)
		2500	20.0 (508)	1.70 (42.0)	1.40 (35.5)	6.30 (159)	17.0 (433)	4.80 (122)	5.70 (145)	4.40 (112)	68.3 (31)
1 1/2 (DN 40)	1 (25.4)	150	18.5 (470)	0.90 (22.5)	0.60 (16.0)	5.00 (127)	13.2 (336)	4.90 (125)	6.10 (155)	4.50 (114)	46.3 (21)
		300/600	19.3 (490)	1.20 (30.0)	0.90 (22.5)	6.10 (155)	14.4 (366)	4.90 (125)	6.10 (155)	4.50 (114)	55.1 (25)
		900/1500	32.4 (822)	1.50 (38.5)	1.30 (32.0)	7.00 (178)	20.7 (527)	4.90 (125)	6.10 (155)	4.50 (114)	187 (85)
		2500	33.0 (838)	2.10 (52.5)	1.80 (44.5)	8.00 (203)	22.2 (563)	6.40 (162)	7.80 (199)	5.90 (150)	209 (95)
2 (DN 50)	1 1/2 (38.1)	150	20.2 (512)	0.90 (24.0)	0.70 (17.5)	6.00 (152)	14.7 (374)	5.60 (142)	7.20 (182)	5.40 (138)	79.4 (36)
		300/600	20.6 (524)	1.30 (33.5)	1.00 (25.5)	6.50 (165)	15.4 (392)	5.60 (142)	7.20 (182)	5.40 (138)	88.2 (40)
		900/1500	27.0 (687)	1.80 (46.5)	1.50 (38.5)	8.50 (216)	18.7 (474)	5.60 (142)	7.20 (184)	5.40 (138)	136 (62)
		2500	37.0 (939)	2.30 (59.0)	2.00 (51.0)	9.30 (235)	22.9 (581)	6.50 (166)	6.90 (175)	9.70 (247)	264 (120)
3 (DN 80) Reduced bore only	2 (50.8)	150	20.4 (517)	1.10 (28.8)	0.90 (22.4)	8.50 (216)	15.1 (384)	5.50 (140)	7.20 (182)	5.40 (138)	90.4 (41)
		300	20.7 (525)	1.40 (34.9)	1.10 (26.9)	9.30 (235)	15.9 (403)	5.50 (140)	7.20 (182)	5.40 (138)	99.2 (45)
		600	21.1 (535)	1.60 (39.8)	1.30 (31.8)	8.30 (210)	16.3 (413)	5.50 (140)	9.10 (230)	7.20 (184)	110 (50)
		900	27.0 (687)	1.80 (46.1)	1.50 (38.1)	9.50 (241)	18.7 (475)	5.50 (140)	9.10 (230)	7.20 (184)	150 (68)
		1500	27.8 (705)	2.20 (55.8)	1.90 (47.8)	10.5 (267)	20.1 (511)	6.40 (163)	9.10 (230)	8.30 (210)	183 (83)
		2500	37.9 (963)	3.00 (76.0)	2.60 (66.5)	12.0 (305)	24.9 (633)	6.40 (163)	10.2 (260)	8.30 (210)	357 (162)

VS03 Series

Ordering Information

Build a process interface valve ordering number by combining the designators as shown below.

All VS03 series valves include a fixed identification tag and are certified to ISO 15848-1 low emissions as standard.

A B C D E F G H J M
VS03 01 SA E 1 C 1 3 C A FE

A Configuration (ball/needle/ball)

- 01 = Full bore
- 02 = Reduced bore
(ball/needle [block/bleed])
- 04 = Full bore
- 05 = Reduced bore

B Materials

Standard

- SA = 316 SS
- CA = Carbon steel
- DA = Duplex SS

Available

- DB = Super Duplex SS
- DE = Super Duplex SS (NORSOK)
- DD = SS Duplex (NORSOK)
- DL = Duplex SS, with duplex needles
- NA = Alloy 400
- NB = Alloy 625
- NC = Alloy 825
- SB = Alloy 6 Moly
- ND = Alloy C-276

C Seats, Stem Seals, Body Seals

- E = PEEK, Graphite/FKM O-ring, Graphite/FKM O-ring^①
- F = PEEK, Graphite/FKM O-ring, Graphite/FKM O-ring^②

^① FKM 90VAA5800

^② FKM 90VAB5800 (low-temperature)

D ASME Flange Class

- 1 = 150
- 2 = 300
- 3 = 600
- 4 = 900 (3 in. flange size **F** only)
- 5 = 900/1500 (1, 1 1/2, or 2 in. flange size **C, D, or E**)
- 5 = 1500 (3 in. flange size **F** only)
- 6 = 2500 (configuration **01**, flange size **C or D** only; configuration **02**, flange size **D or E**)

E Process Connection Size

- C = 1 in. (DN 25) (full bore only; select configuration **01**)
- D = 1 1/2 in. (DN 40)
- E = 2 in. (DN 50)
- F = 3 in. (DN 80) (reduced bore only; select configuration **02**)

F Process Connection Type

- 1 = RF smooth (3.2 to 6.3 μm)
- 2 = RF serrated (6.3 to 12.5 μm)
- 3 = RTJ
- 4 = FF serrated (6.3 to 12.5 μm)
- 5 = FF smooth (3.2 to 6.3 μm)

G Outlet Connection

- 3 = Flange (same as process)

H Bleed Connection

- C = 1/2 in. ffemale NPT
- E = 1/2 in. female NPT with 316 SS bleed valve
- F = 1/2 in. female NPT with duplex SS bleed valve
- J = 1/2 in. female NPT with 316 SS plug
- K = 1/2 in. female NPT with duplex SS plug

J Handle Options

- A = Block, nonlockable levers; bleed, antitamper^①
- B = Block, lockable levers; bleed, antitamper^①
- C = Block, nonlockable levers; bleed, bar
- D = Block, lockable levers; bleed, bar

^① Antitamper key sold separately. See page 30.

M Low Emissions Option

- FE = Low emissions certification per ISO 15848-1
- F2 = ISO 15848-2 production test

Available Options

Option	Description	Designator
Silconert Coating ^①	Chemically inert coating	12457
Positive Material Identification (PMI)	PM2 testing per Swagelok SCS-00209	PM2
Dye Penetrant	Testing and test report available upon request	43100
Magnetic Particle Examination	Testing and test report available upon request	53237

^① Not applicable to Nickel based Alloys, Monel, or Duplex/SuperDuplex materials

VB04 Series

Materials of Construction

Component	Valve Body Materials		
	Stainless Steel	Carbon Steel	Duplex Stainless Steel
	Material Grade/ASTM Specification		
<i>Body</i>	<i>Stainless steel/ A182 F316, F316L SS</i>	<i>Carbon steel/ A350 LF2^③</i>	<i>Duplex stainless steel/ A182 F51</i>
<i>Balls, ball valve end connections, needle valve bonnet</i>	316 SS, 316L SS/ A479		S31803/ A479 ^④
<i>Ball valve stems</i>	316 SS/A479 ^①		S31803/A479
<i>Ball valve seats</i>	PEEK		
<i>Ball valve stem seals</i>	PTFE outer jacket, Elgiloy [®] spring		
<i>Needle</i>	S17400 SS/A564 condition H1150D ^②		
<i>Body seals, needle valve packing, needle valve bonnet seal</i>	Graphite ^⑤		
<i>All other components</i>	316 SS		

Wetted components listed in *italics*.

① VB04 valves with 3/4 in. (20 mm) bore—S17400 SS/A564 condition H1150D.

② Alternate needle material are available.

③ Carbon steel is treated with rust inhibitor.

④ Optional Swagelok end connections are only offered in super duplex stainless steel.

⑤ Optional low emissions configuration supplied with carbon/glass-filled PTFE needle valve packing and bonnet seal.

Pressure-Temperature Ratings

Class 150 to class 2500 in accordance with ASME B16.5; see page 5.

Valve Working Temperatures

- -58 to 400°F (-50 to 204°C) for stainless steel and duplex valve assemblies
- -50 to 400°F (-46 to 204°C) for carbon steel valve assemblies

- ⚠ A packing adjustment may be required periodically to increase service life and to prevent leakage.
- ⚠ Valves that have not been cycled for a period of time may have a higher initial actuation torque.
- ⚠ To increase service life, ensure proper valve performance, and prevent leakage, apply only as much torque as is required to achieve positive shutoff.

VB04 Series

Dimensions

Dimensions are for reference only and are subject to change.

For additional flange dimensions, see page 5.

Raised-Face (RF) Flange Process and Outlet Connections All Bore Sizes

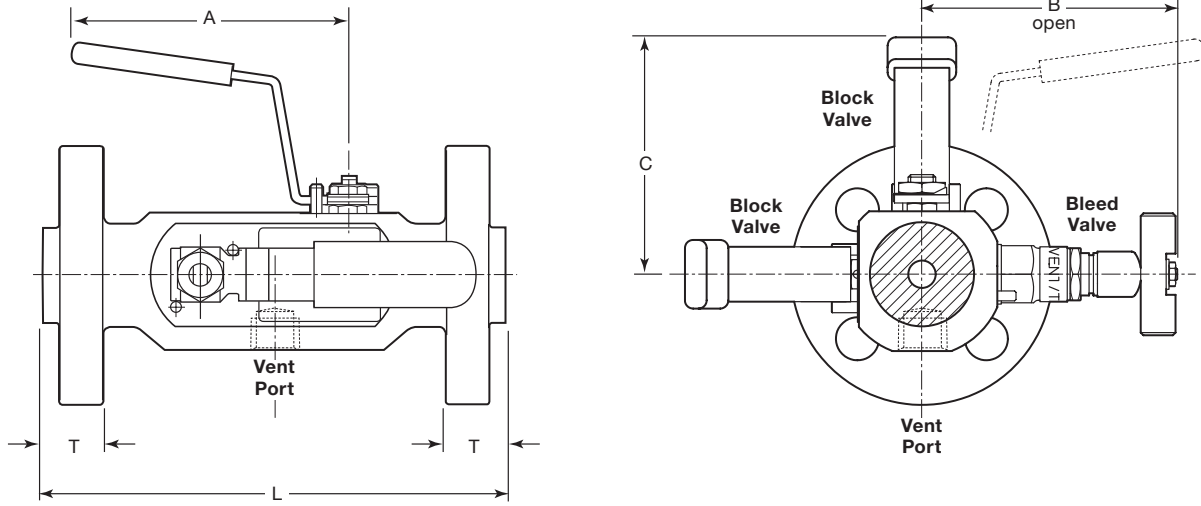

Raised-Face (RF) Flange Process Connection, 1/2 in. Female NPT Outlet Connection 1/2 in. (14 mm) Bore Sizes

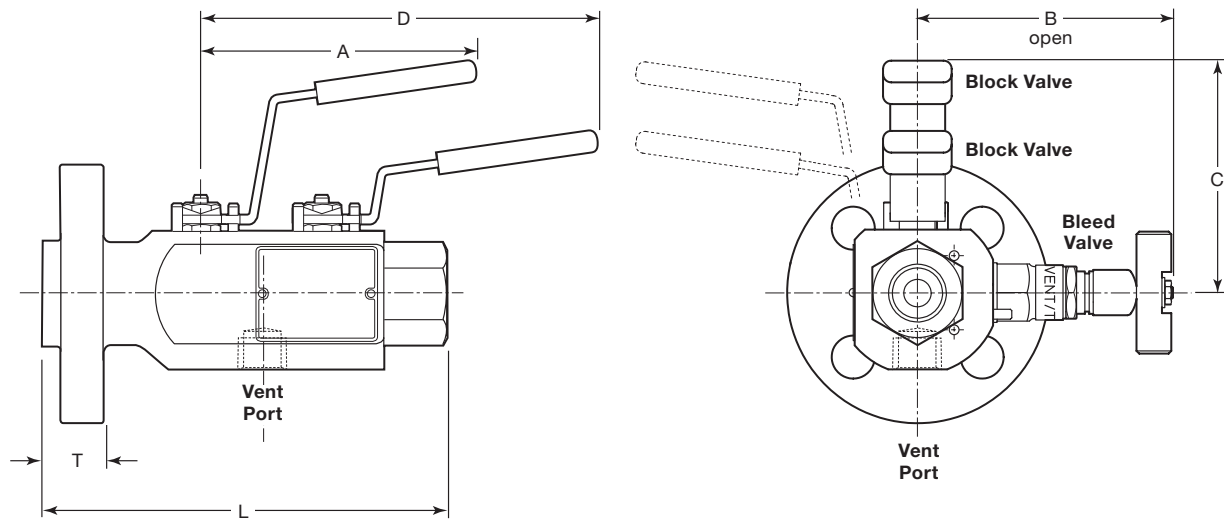

VB04 Series

Dimensions

1/2 in. (14 mm) Bore

Flange Size in.	ASME Class	Dimensions, in. (mm)								Weight lb (kg)									
		A	B	C	D	L		T		Flanges	Flange/NPT								
						Flanges	Flange/NPT	RF Flange	RTJ Flange										
1 (DN 25)	150	4.80 (122)	3.98 (101)	3.88 (98.5)	6.79 (177)	9.10 (231)	7.76 (197)	0.63 (16.2)	0.89 (22.6)	17.0 (7.7)	8.2 (3.7)								
	300/600					9.49 (241)		1.02 (25.9)	1.02 (25.9)	19.4 (8.8)	9.5 (4.3)								
	900/1500					10.3 (261)		1.45 (36.8)	1.45 (36.8)	28.0 (12.7)	14.6 (6.6)								
	2500					10.7 (273)		1.71 (43.5)	1.71 (43.5)	34.2 (16.5)	17.4 (7.9)								
1 1/2 (DN 40)	150					4.80 (122)	3.98 (101)	3.88 (98.5)	6.79 (177)	9.49 (241)	8.15 (207)	0.77 (19.5)	1.02 (25.9)	20.1 (9.1)	10.8 (4.9)				
	300/600									9.88 (251)		1.21 (30.8)	1.21 (30.8)	27.1 (12.3)	14.1 (6.4)				
	900/1500									11.5 (291)	8.35 (212)	1.58 (40.2)	1.58 (40.2)	39.0 (17.7)	20.1 (9.1)				
	2500									12.4 (316)		2.08 (52.9)	2.14 (54.4)	59.5 (27.0)	29.8 (13.5)				
2 (DN 50)	150									4.80 (122)	3.98 (101)	3.88 (98.5)	6.79 (177)	9.49 (241)	8.15 (207)	0.83 (21.1)	1.08 (27.5)	24.1 (10.9)	12.8 (5.8)
	300/600													10.3 (261)		1.33 (33.8)	1.39 (35.3)	31.1 (14.1)	16.1 (7.3)
	900/1500													12.0 (306)	8.35 (212)	1.83 (46.5)	1.89 (48.0)	58.6 (26.6)	29.5 (13.4)
	2500													13.6 (346)	8.74 (222)	2.33 (59.2)	2.39 (60.7)	83.3 (37.8)	41.4 (18.8)

3/4 in. (20 mm) Bore

Flange Size in.	ASME Class	Dimensions, in. (mm)						Weight lb (kg)			
		A	B	C	L	T					
						RF Flange	RTJ Flange				
1 1/2 (DN 40)	150	7.12 (181)	4.25 (108)	5.55 (141)	10.7 (273)	0.77 (19.5)	1.02 (25.9)	29.5 (13.4)			
	300/600					1.21 (30.8)	1.21 (30.8)	35.1 (15.9)			
	900/1500					11.7 (298)	1.58 (40.2)	1.58 (40.2)	46.1 (20.9)		
	2500					12.7 (323)	2.08 (52.9)	2.14 (54.4)	66.1 (30.0)		
2 (DN 50)	150				7.12 (181)	4.25 (108)	5.55 (141)	10.7 (273)	0.83 (21.1)	1.08 (27.5)	33.5 (15.2)
	300/600								1.33 (33.8)	1.39 (35.3)	38.4 (17.4)
	900/1500							12.5 (318)	1.83 (46.5)	1.89 (48.0)	65.9 (29.9)
	2500							14.7 (373)	2.33 (59.2)	2.39 (60.7)	91.7 (41.6)

VB04 Series

Ordering Information for Flange by Flange and Flange by Thread, Including Swagelok Tube Fittings

Build a process interface valve ordering number by combining the designators as shown below.

A B C D E F G H J K L M
VB04 02 SA D 1 D 1 C C B S 450 LE

A Configuration

(ball/needle/ball)

02 = 1/2 in. (14 mm) bore (select process connection size; **C**, **D**, or **E**)

03 = 3/4 in. (20 mm) bore (select process connection size; **D** or **E**)

(ball/needle [block/bleed])

05 = 1/2 in. (14 mm) bore (select process connection size; **C**, **D**, or **E**)

B Materials

Standard

SA = 316 SS

CA = Carbon steel

DA = Duplex SS

Available

DB = Super Duplex SS

DE = Super Duplex SS (NORSOK)

DD = Duplex SS (NORSOK)

DL = Duplex SS, with Duplex needles

NA = Alloy 400

NB = Alloy 625

NC = Alloy 825

SB = Alloy 6 Moly

C Seats, Stem Seals, Body Seals

D = PEEK, PTFE, Graphite

D ASME Flange Class

1 = 150

3 = 300/600

5 = 900/1500

6 = 2500

E Process Connection Size

C = 1 in. (DN 25)

D = 1 1/2 in. (DN 40)

E = 2 in. (DN 50)

F Process Connection Type

1 = Flange, RF smooth
(3.2 to 6.3 μm)

2 = Flange, RF serrated
(6.3 to 12.5 μm)

3 = Flange, RTJ

G Outlet Connection

3 = Flange

C = 1/2 in. female NPT

D = 3/4 in. female NPT

M = 1/2 in. male NPT

N = 3/4 in. male NPT

R = 1/2 in. Swagelok^①

S = 3/4 in. Swagelok^{①③}

W = 12 mm Swagelok^③

Y = 20 mm Swagelok^{①②}

^① Pressure rating may be limited by end connection. Refer to Swagelok *Tubing Data* catalog, MS-01-107, for additional information.

^② Not available in Duplex or Super Duplex valve configurations.

^③ Not available in Duplex valve configurations.

H Bleed Connection

C = 1/2 in. female NPT

J Handle Options

B = Block, lockable levers; bleed, antitamper^①

D = Block, lockable levers; bleed, bar

^① Antitamper key sold separately. See page 30.

K Injection and Sampling Probe Options

Probes are available on VB04 series valves with 1/2 in. (14 mm) bores and process connection sizes 1 1/2 in. (DN40) and larger.

Omit designator if no probe is required.

S = Probe, 45° end preparation

R = Probe, 90° end preparation

L Injection and Sampling Probe Length

Insert probe length in millimeters, in whole numbers, up to a maximum of three characters.

*Minimum length may apply,
Maximum length = 600 mm*

Omit designator if no probe is required.

M Low Emissions Option

LE = Low emissions certification per API 641 and API 624 available

VB04 Series

Ordering Information Thread by Thread, Including Swagelok Tube Fittings

Build a process interface valve ordering number by combining the designators as shown below.

VB04 **A** **B** **C** **D** **E** **F** **G** **H** **J** **M**
02 SA D 6 S S S C B LE

A Configuration

(ball/needle/ball)

02 = 1/2 in. (14 mm) bore

03 = 3/4 in. (20 mm) bore

(ball/needle [block/bleed])

05 = 1/2 in. (14 mm) bore

B Materials

Standard

SA = 316 SS

CA = Carbon steel

DA = Duplex SS

Available

DB = Super Duplex SS

DE = Super Duplex SS (NORSOK)

DD = SS Duplex (NORSOK)

DL = Duplex SS, with Duplex needles

NA = Alloy 400

NB = Alloy 625

NC = Alloy 825

SB = Alloy 6 Moly

C Seats, Stem Seals, Body Seals

D = PEEK, PTFE, Graphite

D Pressure Class

6 = 2500

E End Configuration

S = Thread-by-thread connection

F Inlet Connection

C = 1/2 in. female NPT

D = 3/4 in. female NPT

M = 1/2 in. male NPT

N = 3/4 in. male NPT

R = 1/2 in. Swagelok^③

S = 3/4 in. Swagelok^{①③}

W = 12 mm Swagelok^③

Y = 20 mm Swagelok^{①②}

① Pressure rating may be limited by end connection. Refer to Swagelok *Tubing Data* catalog, MS-01-107, for additional information.

② Not available in Duplex or Super Duplex valve configurations.

③ Not available in Duplex valve configurations.

G Outlet Connection

C = 1/2 in. female NPT

D = 3/4 in. female NPT

M = 1/2 in. male NPT

N = 3/4 in. male NPT

R = 1/2 in. Swagelok^③

S = 3/4 in. Swagelok^{①③}

W = 12 mm Swagelok^③

Y = 20 mm Swagelok^{①②}

① Pressure rating may be limited by end connection. Refer to Swagelok *Tubing Data* catalog, MS-01-107, for additional information.

② Not available in Duplex or Super Duplex valve configurations.

③ Not available in Duplex valve configurations.

H Bleed Connection

C = 1/2 in. female NPT

J Handle Options

B = Block, lockable levers; bleed, antitamper^①

D = Block, lockable levers; bleed, bar

① Antitamper key sold separately, see page 30.

M Low Emissions Option

LE = Low emissions certification per API 641 and API 624 available

VB04 Series

Options

Chemical Injection and Process Sampling Options

Select process interface valves may be ordered in optional injection or sampling valve configurations, providing double block and bleed protection for specialized applications.

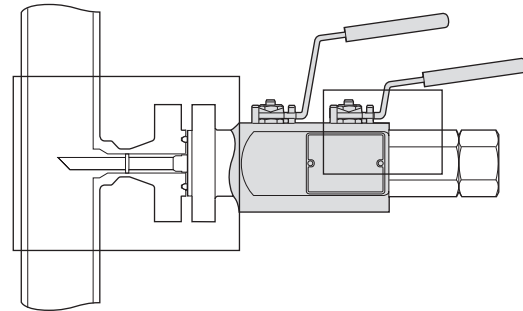

**Injection Valve
With Integral Check Valve
and NPT Connection**

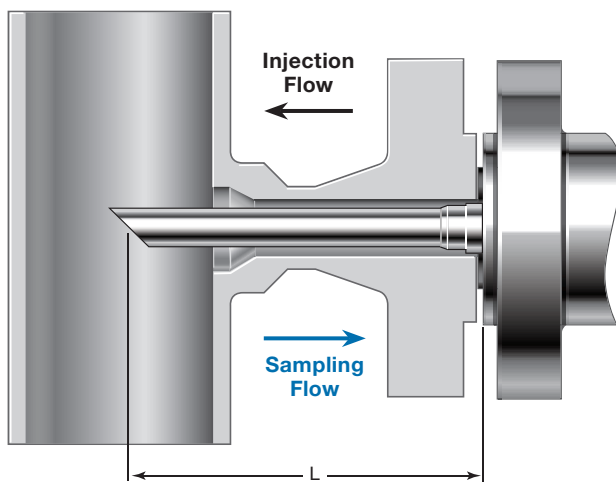

**Injection Valve Flow
Compared With
Sampling Valve Flow**

**Retaining Spring
Stabilizes Probe
in Valve Body**
(shown partially inserted
for demonstration
purposes)

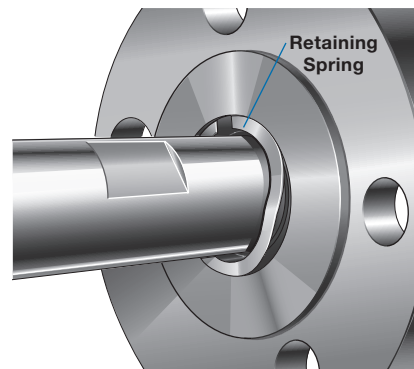

A process interface valve fitted with an injection probe and a check valve allows fluids to be dispersed into the process stream while providing protection against backflow of process fluids.

The sampling valve probe draws process fluid from the flow stream.

Standard injection and sampling probes of 1/2 in. schedule 40 pipe are available on VB04 series valves with 3/8 in. (9.5 mm) and 1/2 in. (14 mm) bores. They are limited to process connection sizes 1 1/2 in. (DN40) and larger. End preparations of 45° and 90° are available.

Available Options

Option	Description	Designator
Helium Leak Testing ^①	Low-pressure helium testing per Swagelok SCS-00014 and SCS-00150	A0083
Positive Material Identification (PMI) ^①	PM2 testing per Swagelok SCS-00209	PM2
Identification Tag	Tag per customer marking (Tag size: 60 mm x 11.5 mm)	A0042
Hydrostatic Test Certificate ^①	Certificate per ISO 15156 (3.1)	–
High-Pressure Gas Testing to Support 1.1x Shell Pressure ^①	Testing and test report available upon request	–
Dye Penetrant	Testing and test report available upon request	43100
Magnetic Particle Examination ^②	Testing and test report available upon request	53237
Low Emissions per API 641/624 ^③	Low emissions certification per applicable API specification available	LE

^① For more information, contact your authorized Swagelok representative.

^② Dye penetrant and magnetic particle examination tests are standard on select configurations.

^③ For more information, see materials of construction.

VS04 Series

Materials of Construction

Component	Valve Body Materials		
	Stainless Steel	Carbon Steel ^②	Duplex Stainless Steel
	Material Grade/ASTM Specification		
<i>Body</i>	316/316L SS/ ASTM A479	LF2 ^① / ASTM A350	S31803/ASTM A479
<i>Balls, ball valve end connections, needle valve bonnet</i>	316/316L SS/ASTM A479		S31803/ A479 ^③
<i>Ball valve stems</i>	316/316L SS/ASTM A479		S31803 ^③ /ASTM A479
<i>Ball valve seats</i>	PEEK		
<i>Ball valve stem seals</i>	Graphite		
<i>Needle</i>	S17400 SS/A564 condition H1150D ^④		
<i>Body seals</i>	see <i>Body Material</i>		
<i>needle valve packing, needle valve bonnet seal</i>	Graphite		
<i>All other components</i>	316 SS		

- ⚠ A packing adjustment may be required periodically to increase service life and to prevent leakage.
- ⚠ Valves that have not been cycled for a period of time may have a higher initial actuation torque.
- ⚠ To increase service life, ensure proper valve performance, and prevent leakage, apply only as much torque as is required to achieve positive shutoff.

Wetted components listed in *italics*.

- ① Optional low emissions configurations supplied per ISO 15848-1 and ISO 15848-2.
- ② Not available in thread-by-thread configurations.
- ③ Optional Swagelok end connections are only offered in super duplex stainless steel.
- ④ Alternate needle materials are available.

Pressure-Temperature Ratings

Class 150 to class 2500 in accordance with ASME B16.5;
see page 5.

Valve Working Temperatures

- -65 to 500°F (-54 to 260°C)

VS04 Series

Dimensions

Dimensions are for reference only and are subject to change.

For additional flange dimensions, see page 5.

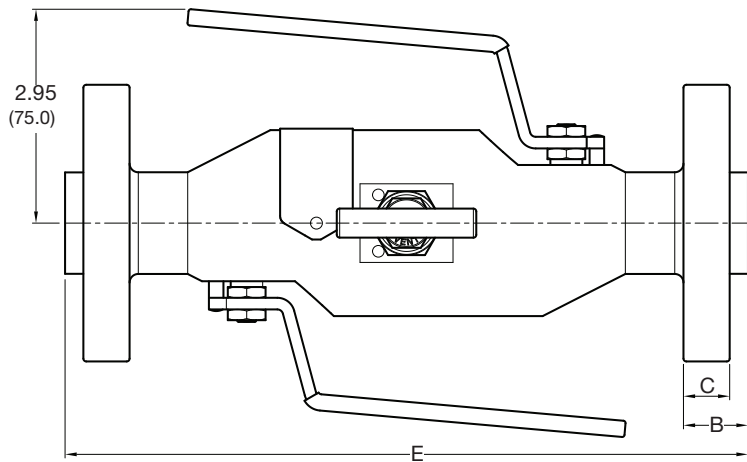

3/8 in. (9.5 mm) Bore Raised Face (RF) and (RJ) Flange

Flange/Thread		Dimensions, in. (mm)					
Flange Size in.	Class	B for RF	B for RJ	C	E for RF	E for RJ	Weight lb (kg)
1/2 (DN 15)	150	0.44 (11.1)	(-)	0.37 (9.6)	9.13 (232)	(-)	12.1 (4.5)
	300/600	0.81 (20.7)	0.78 (19.85)	0.56 (14.3)	9.13 (232)	9.07 (230)	12.1 (4.5)
	900/1500	1.13 (28.7)	1.13 (28.7)	0.88 (22.3)	9.89 (251)	9.89 (251)	18.8 (7.0)
	2500	1.44 (36.6)	1.44 (36.6)	1.19 (30.2)	10.4 (264)	10.4 (264)	18.8 (7.0)
3/4 (DN 20)	150	0.50 (12.7)	(-)	0.44 (11.1)	9.13 (232)	(-)	13.4 (5.0)
	300/600	0.87 (22.1)	0.87 (22.1)	0.62 (15.7)	9.13 (232)	9.13 (232)	16.1 (6.0)
	900/1500	1.25 (31.8)	1.25 (31.8)	1.00 (25.4)	9.88 (251)	9.88 (251)	22.8 (8.5)
	2500	1.50 (38.1)	1.50 (38.1)	1.25 (31.8)	10.4 (264)	10.4 (264)	29.5 (11.0)
1 (DN 25)	150	0.56 (14.2)	0.75 (19.0)	0.50 (12.6)	9.13 (232)	9.50 (241)	16.1 (6.0)
	300/600	0.94 (24)	0.94 (23.9)	0.69 (17.5)	9.89 (251)	9.89 (251)	18.8 (7.0)
	900/1500	1.40 (34.8)	1.40 (34.8)	1.12 (28.4)	10.4 (264)	10.4 (264)	29.5 (11.0)
	2500	1.63 (41.4)	1.63 (41.4)	1.38 (35.0)	10.4 (264)	10.4 (264)	38.8 (14.5)
1 1/2 (DN 40)	150	0.69 (17.5)	0.88 (22.3)	0.62 (15.9)	9.12 (232)	9.51 (242)	20.1 (7.5)
	300/600	1.13 (28.7)	1.13 (28.7)	0.88 (22.3)	10.0 (254)	10.0 (254)	28.1 (10.5)
	900/1500	1.50 (38.1)	1.50 (38.1)	1.25 (31.7)	10.4 (264)	10.4 (264)	42.9 (16.0)
	2500	2.00 (50.8)	2.06 (52.3)	1.75 (44.4)	12.2 (311)	12.4 (314)	71.0 (26.5)
2 (DN 50)	150	0.75 (19.05)	0.94 (23.8)	0.68 (17.4)	9.8 (251)	10.2 (260)	26.8 (10.0)
	300/600	1.25 (31.8)	1.31 (33.3)	1.00 (25.4)	10.4 (264)	10.5 (267)	30.8 (11.5)
	900/1500	1.75 (44.5)	1.81 (46.02)	1.50 (38.1)	12.2 (311)	12.4 (314)	69.7 (26.0)
	2500	2.25 (57.2)	2.31 (58.7)	2.00 (50.8)	13.0 (331)	13.2 (334)	100 (37.5)

VS04 Series

Dimensions

Dimensions are for reference only and are subject to change.

For additional flange dimensions, see page 5.

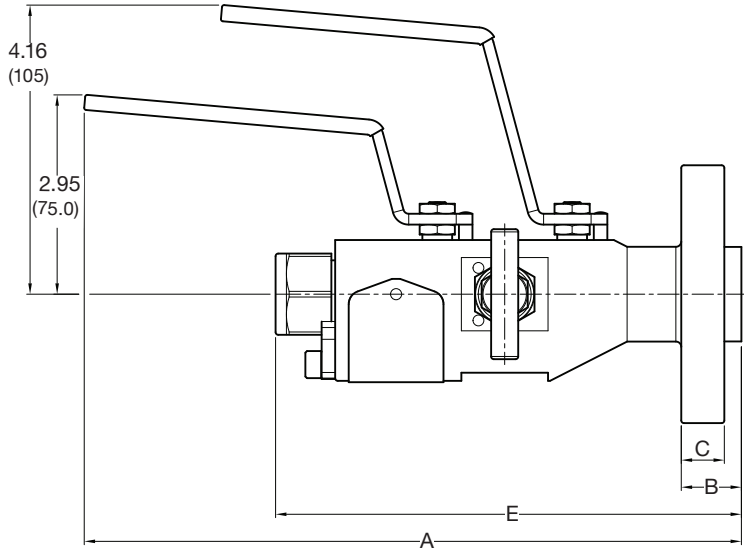

3/8 in. (9.5 mm) Bore
Raised Face (RF) and (RJ) Flange by Thread

Flange/Thread		Dimensions, in. (mm)						
Flange Size in.	Class	A	B for RF	B for RJ	C	E for RF	E for RJ	Weight lb (kg)
1/2 (DN 15)	150	8.87 (225)	0.44 (11.1)	(-)	0.37 (9.6)	6.71 (170)	(-)	7.33 (2.7)
	300/600	8.87 (225)	0.81 (20.7)	0.78 (19.8)	0.56 (14.3)	6.96 (177)	6.93 (176)	8.04 (3.0)
	900/1500	9.27 (235)	1.13 (28.7)	1.13 (28.7)	0.88 (22.3)	7.17 (182)	7.17 (182)	10.7 (4.0)
	2500	9.66 (245)	1.44 (36.6)	1.44 (36.6)	1.19 (30.2)	7.50 (190)	7.50 (190)	14.7 (5.5)
3/4 (DN 20)	150	8.87 (225)	0.50 (12.7)	(-)	0.44 (11.1)	6.71 (170)	(-)	8.04 (3.0)
	300/600	8.87 (225)	0.87 (22.1)	0.87 (22.1)	0.62 (15.7)	7.00 (178)	7.00 (178)	9.38 (3.5)
	900/1500	9.27 (235)	1.25 (31.8)	1.25 (31.8)	1.00 (25.4)	7.11 (180)	7.11 (180)	12.6 (4.7)
	2500	9.66 (245)	1.50 (38.1)	1.50 (38.1)	1.25 (31.75)	7.50 (190)	7.50 (190)	16.1 (6.0)
1 (DN 25)	150	8.87 (225)	0.56 (14.2)	0.75 (19.0)	0.50 (12.6)	6.70 (170)	6.90 (175)	9.38 (3.5)
	300/600	8.87 (225)	0.94 (24.0)	0.94 (23.9)	0.69 (17.5)	6.71 (171)	6.71 (171)	10.7 (4.0)
	900/1500	9.66 (245)	1.40 (34.8)	1.40 (34.8)	1.12 (28.4)	7.50 (190)	7.50 (190)	16.9 (6.3)
	2500	9.66 (245)	1.63 (41.4)	1.63 (41.4)	1.38 (35)	7.51 (191)	7.51 (191)	20.1 (7.5)
1 1/2 (DN 40)	150	8.87 (225)	0.69 (17.5)	0.88 (22.3)	0.62 (15.9)	6.71 (170)	6.96 (175)	12.1 (4.5)
	300/600	9.27 (235)	1.13 (28.7)	1.13 (28.7)	0.88 (22.3)	7.42 (188)	7.42 (188)	15.5 (5.8)
	900/1500	10.13 (257)	1.50 (38.1)	1.50 (38.1)	1.25 (31.7)	8.00 (202)	8.00 (202)	24.1 (9.0)
	2500	10.84 (275)	2.00 (50.8)	2.06 (52.3)	1.75 (44.4)	8.70 (220.5)	8.70 (222)	37.5 (14)
2 (DN 50)	150	9.27 (235)	0.75 (19.0)	0.94 (23.8)	0.68 (17.4)	7.10 (180)	7.30 (185)	15.5 (5.8)
	300/600	9.27 (235)	1.25 (31.8)	1.31 (33.3)	1.00 (25.4)	7.10 (180)	7.20 (182)	18.8 (7.0)
	900/1500	10.84 (275)	1.75 (44.5)	1.81 (46.0)	1.50 (38.1)	8.70 (220)	8.74 (222)	37.5 (14)
	2500	10.84 (275)	2.25 (57.2)	2.31 (58.7)	2.00 (50.8)	8.70 (220)	8.74 (222)	50.9 (19)

VS04 Series With Available Sampling or Injection Probe

Ordering Information for Flange by Flange and Flange by Thread, Including Swagelok Tube Fittings

Build a VS04 series process interface valve ordering number by combining the designators as shown below.

A B C D E F G H J K L M
VS04 01 SA E 1 D 1 C C A S 450 FE

A Configuration

(ball/needle/ball)

01 = 3/8 in. (9.5 mm) bore

(ball/needle [block/bleed])

04 = 3/8 in. (9.5 mm) bore

(ball/ball [block/block])

31 = 3/8 in. (9.5 mm) bore^①

Integral check valve

(ball/needle/ball/check)

07 = 3/8 in. (9.5 mm) bore

^① Available by special request.

B Materials

Standard

SA = 316 SS

CA = Carbon steel

DA = Duplex SS

Available

DB = Super Duplex SS

DE = Super Duplex SS (NORSOK)

DD = SS Duplex (NORSOK)

DL = Duplex SS, with Duplex needles

NA = Alloy 400

NB = Alloy 625

NC = Alloy 825

SB = Alloy 6 Moly

ND = Alloy C-276

C Seats, Stem Seals, Body Seals, Needle Material

E = PEEK, Graphite, Metallic^①, same as body material

K = PEEK, Graphite, Metallic, 625

P = PEEK, Graphite, Metallic, C-276

R = PEEK, Graphite, Metallic, 254

T = PEEK, Graphite, Metallic, M400

^① Metallic body seals are the same as selected body material.

D ASME Flange Class

1 = 150

3 = 300/600

5 = 900/1500

6 = 2500

E Process Connection Size

A = 1/2 in. (DN 15)

B = 3/4 in. (DN 20)

C = 1 in. (DN 25)

D = 1 1/2 in. (DN 40)

E = 2 in. (DN 50)

F Process Connection Type

1 = Flange, RF smooth (3.2 to 6.3 μm)

2 = Flange, RF serrated (6.3 to 12.5 μm)

3 = Flange, RTJ

4 = Flange, FF serrated (6.3 to 12.5 μm)

5 = Flange, FF smooth (3.2 to 6.3 μm)

G Outlet Connection

3 = Flange

A = 1/4 in. female NPT

B = 3/8 in. female NPT

C = 1/2 in. female NPT

D = 3/4 in. female NPT

F = G1/4^①

G = G1/2^①

L = 1/4 in. male NPT

M = 1/2 in. male NPT

N = 3/4 in. male NPT

P = 1/4 in. Swagelok^③

Q = 3/8 in. Swagelok^③

R = 1/2 in. Swagelok^③

S = 3/4 in. Swagelok^{②③}

U = 6 mm Swagelok^③

V = 10 mm Swagelok^③

W = 12 mm Swagelok^③

Y = 20 mm Swagelok^{②③}

^① Compatible with Swagelok RS and RP fittings.

^② Pressure rating may be limited by end connection. Refer to Swagelok *Tubing Data* catalog, [MS-01-107](#), for additional information.

^③ Duplex configurations will be supplied with Super Duplex end connections.

H Bleed Connection

C = 1/2 in. female NPT

E = 1/2 in. female NPT with 316 SS bleed valve

F = 1/2 in. female NPT with duplex SS bleed valve

J = 1/2 in. female NPT with 316 SS plug

K = 1/2 in. female NPT with duplex SS plug

J Handle Options

A = Block, nonlockable levers; bleed, antitamper^①

B = Block, lockable levers; bleed, antitamper^①

C = Block, nonlockable levers; bleed, bar

D = Block, lockable levers; bleed, bar

^① Antitamper key sold separately. See page 30.

K Injection and Sampling Probe Options

Probes are available on VS04 series valves with 3/8 in. (9.5 mm) bores and process connection sizes 1 1/2 in. (DN40) and larger. Probe diameters include:

- 1/2 in. schedule 40^①
- 1/2 in. schedule 160
- 3/8 in. schedule 80

Omit designator if no probe is required.

S = Probe, 45° end preparation

R = Probe, 90° end preparation

^① Probes in duplex, superduplex and nickel based alloys may have limited availability.

L Injection and Sampling Probe Length

Insert probe length in millimeters.

Minimum length = 150 mm

Maximum length = 500 mm (50 mm increments)

Omit designator if no probe is required.

M Low Emissions Options

FE = Low emissions certification per ISO 15848-1

F2 = ISO-15848-2 production test

VS04 Series

Ordering Information Thread by Thread, Including Swagelok Tube Fittings

Build a process interface valve ordering number by combining the designators as shown below.

A B C D E F G H J K
VS04 01 SA E 6 S S S C A FE

A Configuration

(ball/needle/ball)

01 = 3/8 in. (9.5 mm) bore

(ball/needle [block/bleed])

04 = 3/8 in. (9.5 mm) bore

(ball/ball [block/block])

31 = 3/8 in. (9.5 mm) bore^①

^① Available by special request.

B Materials

Standard

SA = 316 SS

DA = Duplex SS

Available

DB = Super Duplex SS

DE = Super Duplex SS (NORSOK)

DD = SS Duplex (NORSOK)

DL = Duplex SS, with Duplex needles

NA = Alloy 400

NB = Alloy 625

NC = Alloy 825

SB = Alloy 6 Moly

ND = Alloy C-276

C Seats, Stem Seals, Body Seals, Needle Material

E = PEEK, Graphite, Metallic^①, same as body material

K = PEEK, Graphite, Metallic, 625

P = PEEK, Graphite, Metallic, C-276

R = PEEK, Graphite, Metallic, 254

T = PEEK, Graphite, Metallic, M400

^① Metallic body seals are the same as selected body material.

D Pressure Class

6 = 2500

E End Configuration

S = Thread-by-thread connection

F Inlet Connection

A = 1/4 in. female NPT

B = 3/8 in. female NPT

C = 1/2 in. female NPT

D = 3/4 in. female NPT

F = G1/4^①

G = G1/2^①

L = 1/4 in. male NPT

M = 1/2 in. male NPT

N = 3/4 in. male NPT

P = 1/4 in. Swagelok^③

Q = 3/8 in. Swagelok^③

R = 1/2 in. Swagelok^③

S = 3/4 in. Swagelok^{②③}

U = 6 mm Swagelok^③

V = 10 mm Swagelok^③

W = 12 mm Swagelok^③

Y = 20 mm Swagelok^③

^① Compatible with Swagelok RS and RP fittings.

^② Pressure rating may be limited by end connection. Refer to Swagelok *Tubing Data* catalog, [MS-01-107](#), for additional information.

^③ Duplex configurations will be supplied with Super Duplex end connections.

G Outlet Connection

A = 1/4 in. female NPT

B = 3/8 in. female NPT

C = 1/2 in. female NPT

D = 3/4 in. female NPT

F = G1/4^①

G = G1/2^①

L = 1/4 in. male NPT

M = 1/2 in. male NPT

N = 3/4 in. male NPT

P = 1/4 in. Swagelok^③

Q = 3/8 in. Swagelok^③

R = 1/2 in. Swagelok^③

S = 3/4 in. Swagelok^{②③}

U = 6 mm Swagelok^③

V = 10 mm Swagelok^③

W = 12 mm Swagelok^③

Y = 20 mm Swagelok^③

^① Compatible with Swagelok RS and RP fittings.

^② Pressure rating may be limited by end connection. Refer to Swagelok *Tubing Data* catalog, [MS-01-107](#), for additional information.

^③ Duplex configurations will be supplied with Super Duplex end connections.

H Bleed Connection

C = 1/2 in. female NPT

E = 1/2 in. female NPT with 316 SS bleed valve

F = 1/2 in. female NPT with duplex SS bleed valve

J = 1/2 in. female NPT with 316 SS plug

K = 1/2 in. female NPT with duplex SS plug

J Handle Options

A = Block, nonlockable levers; bleed, antitamper^①

B = Block, lockable levers; bleed, antitamper^①

C = Block, nonlockable levers; bleed, bar

D = Block, lockable levers; bleed, bar

^① Antitamper key sold separately. See page 30.

K Low Emissions Options

FE = Low emissions certification per ISO 15848-1

F2 = ISO-15848-2 production test

Available Options for VS04 Series Flange by Flange and Flange by Thread

Option	Description	Designator
SilcoNert Coating ^①	Chemically-inert coating	12457
Positive Material Identification (PMI)	PM2 testing per Swagelok SCS-00209	PM2
Dye Penetrant	Testing and test report available upon request	43100
Magnetic Particle Examination	Testing and test report available upon request	53237

^① VS04 flange by flange-and-flange by thread valves include a fixed identification tag.
Not applicable to Nickel based Alloys, Monel, or Duplex/SuperDuplex materials.

Available Options for VS04 Series Thread by Thread

Option	Description	Designator
SilcoNert Coating ^①	Chemically inert coating	12457
Positive Material Identification (PMI)	PM2 testing per Swagelok SCS-00209	PM2
Dye Penetrant	Testing and test report available upon request	43100

^① VS04 thread-by-thread valves have laser-etched identification markings.
Not applicable to Nickel based Alloys, Monel, or Duplex/SuperDuplex materials.

Process Monoflanges

Swagelok process monoflanges replace multivalve assemblies with single, flange-mounted manifold configurations. The main advantages over a typical system include compactness and weight savings, which can reduce stress from loading and vibration; fewer potential leak points; and reduced installation and maintenance times.

Features

- Compact block, block and bleed, and double block and bleed assemblies with minimal potential leak points
- Outside screw and yoke (OS&Y) bolted-bonnet (MS02 series) and integral screwed-bonnet (MS03 series) construction.
- Compatible with ASME B16.5 flange connections from 1/2 to 2 in. (DN 15 to DN 50), RF and RTJ
- Antiblowout valve stems and nonrotating needles
- Hydrostatic test certificates complete with full chemical and physical material certifications available
- Low emissions certification per ISO 15848-1, 15848-2 available

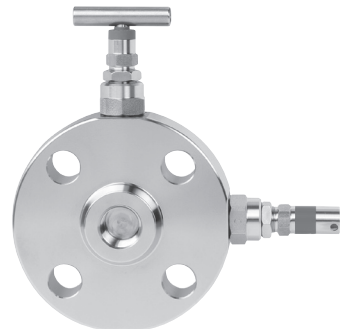
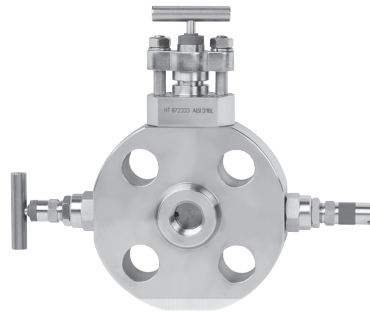

Materials of Construction

Component	Valve Body Materials		
	Stainless Steel	Carbon Steel	Duplex Stainless Steel
	Material Grade/ASTM Specification		
Body	316/316L SS/A479	LF2 ^② /A350	S31803/A479
Bonnet	316/316L SS/A479	316/316L SS/A479	S31803/A479
Bonnet seal, gland packing	316L SS		
Packing	Graphite, PTFE, RTFE ^①		
Needle	S17400 SS/A564 condition H1150D ^③		
Stem	316L SS		
Bonnet bolts (MN02 series)	B8M Class 1/A193	B8M Class 1/A193	B8M Class 1/A193
All other components	316 SS		

Wetted components listed in *italics*.

① Optional low emissions configurations supplied per ISO 15848-1.

② Carbon Steel is treated with rust inhibitor.

③ Alternate needle materials are available.

Duplex Elevated Temperature Rating

If duplex stainless steel is exposed to temperatures exceeding 536°F (280°C) for prolonged periods, the microstructure changes, which results in a reduction in impact strength. For pressure vessel applications, 536°F (280°C) is required as a maximum according to VdTUV-Wb 418 and NGS 1606.

- ⚠ **A packing adjustment may be required periodically to increase service life and to prevent leakage.**
- ⚠ **Valves that have not been cycled for a period of time may have a higher initial actuation torque.**
- ⚠ **To increase service life, ensure proper valve performance, and prevent leakage, apply only as much torque as is required to achieve positive shutoff.**

Pressure-Temperature Ratings

Class 150 to class 2500, up to working temperatures listed below, in accordance with ASME B16.5; see page 5.

Valve Working Temperatures

- -65 to 400°F (-54 to 204°C) for PTFE packing material
- -65 to 1000°F (-54 to 538°C) for Graphite packing material

Process Monoflanges

Configurations

Process monoflanges comprise:

- A primary block valve of OS&Y bolted-bonnet needle or integral screwed-bonnet needle valve construction
- As ordered, a secondary block valve and a bleed valve of integral screwed-bonnet needle valve construction

OS&Y bolted-bonnet (MS02 series) monoflanges are shown; configurations are also available in integral screwed-bonnet (MS03 series) monoflanges.

Block Valve

- OS&Y bolted-bonnet or screwed-bonnet primary isolating process valve

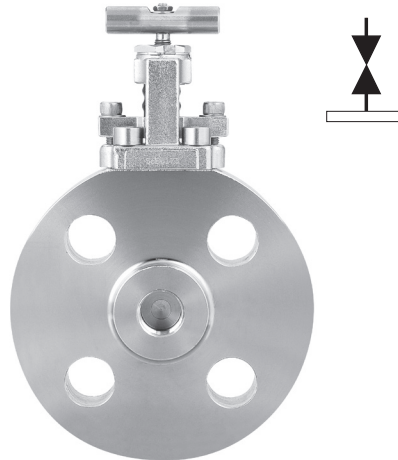

Block and Bleed Valve

- OS&Y bolted-bonnet or screwed-bonnet primary isolating process valve
- Screwed-bonnet vent valve (bar or antitamper handle)

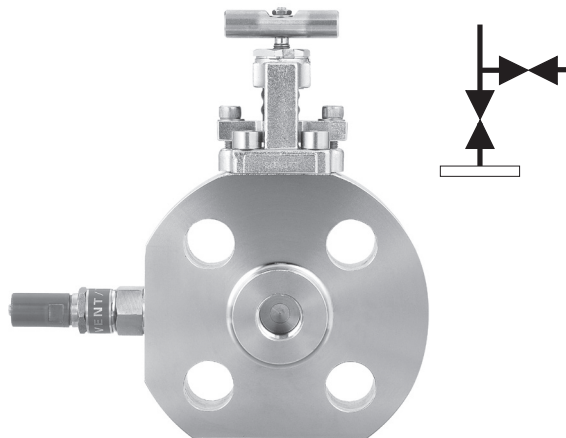

Double Block and Bleed Valve

- OS&Y bolted-bonnet or screwed-bonnet primary isolating process valve
- Secondary OS&Y bolted bonnet or screwed bonnet
- Needle valve vent (bar or antitamper handle)

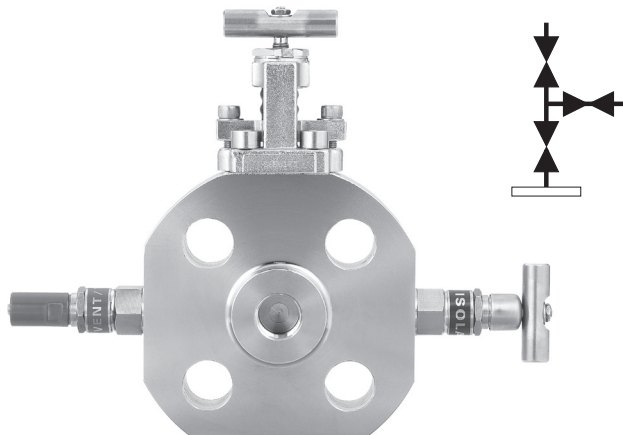

Process Monoflanges

Dimensions, Outside Screw and Yoke (OS&Y) Bolted-Bonnet Assemblies (MS02 Series)

Dimensions are for reference only and are subject to change.

For additional flange dimensions, see page 5.

MS02 Series (OS&Y Bolted-Bonnet) Bore Sizes

All bores 0.2 in. (5 mm)

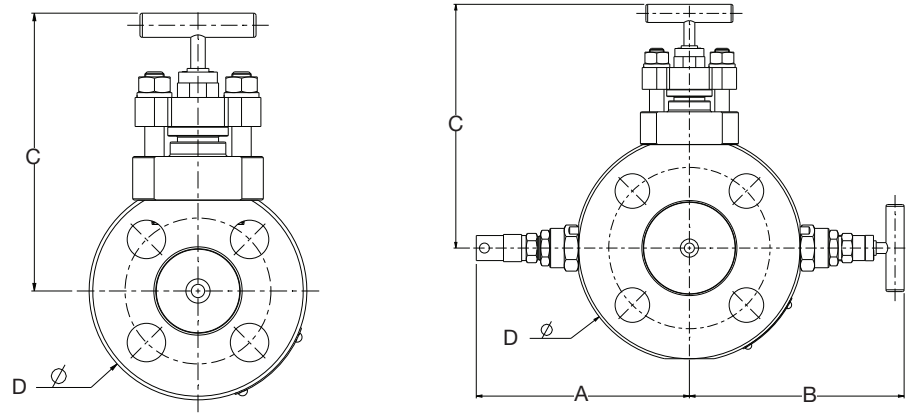

For DBB sizes DN50 Class 300 and up, the secondary block and vent valves are oriented 45 degrees from the primary block valve.

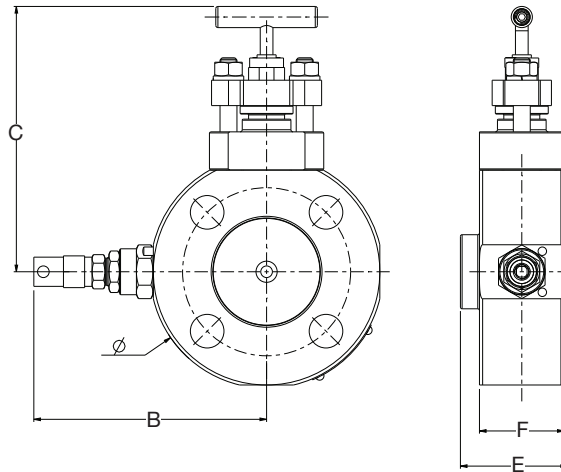

MS02 Monoflange		Dimensions, in. (mm)							
Flange Size in.	Class	A	B	C	∅ D	E for RF	E for RJ	F	Weight lb (kg)
1/2 (DN 15)	150	3.94 (100)	3.78 (96.0)	4.45 (113)	3.50 (8.9)	2.00 (50.6)	–	1.57 (40)	4.85 (2.2)
	300/600	4.06 (103)	3.91 (99.3)	4.6 (116.8)	3.75 (95.2)	2.18 (55.4)	2.15 (54.5)		5.51 (2.5)
	900/1500	4.57 (116)	4.42 (112)	5.17 (131.4)	4.75 (121)	2.18 (55.4)	2.18 (55.4)		7.94 (3.6)
	2500	4.76 (121)	4.61 (117)	5.45 (138.5)	5.25 (133)	2.18 (55.4)	2.18 (55.4)		10.58 (4.8)
3/4 (DN 20)	150	4.13 (105)	3.98 (101)	4.68 (118.8)	3.87 (98.4)	2.00 (50.6)	–		6.83 (3.1)
	300/600	4.53 (115)	4.36 (111)	5.1 (129.6)	4.62 (118)	2.18 (55.4)	2.18 (55.4)		7.94 (3.6)
	900/1500	4.76 (121)	4.61 (117)	5.38 (136.7)	5.12 (130)	2.18 (55.4)	2.18 (55.4)		9.48 (4.3)
	2500	4.8 (122)	4.65 (118)	5.59 (142)	5.50 (140)	2.18 (55.4)	2.18 (55.4)		11.46 (5.2)
1 (DN 25)	150	4.32 (110)	4.17 (106)	4.89 (124.2)	4.25 (108)	2.00 (50.6)	2.18 (55.4)		7.28 (3.3)
	300/600	4.65 (118)	4.49 (114)	5.24 (133)	4.87 (124)	2.18 (55.4)	2.18 (55.4)		9.92 (4.5)
	900/1500	5.15 (131)	5.00 (127)	5.79 (147)	5.87 (149)	2.18 (55.4)	2.18 (55.4)		12.35 (5.6)
	2500	5.34 (136)	5.20 (132)	5.98 (152)	6.25 (159)	2.18 (55.4)	2.18 (55.4)		14.33 (6.5)
1 1/2 (DN 40)	150	4.70 (120)	4.55 (116)	5.31 (135)	5.00 (127)	2.00 (50.6)	2.18 (55.4)		11.68 (5.3)
	300/600	5.28 (134)	5.12 (130)	5.91 (150.2)	6.12 (156)	2.18 (55.4)	2.18 (55.4)		11.68 (5.3)
	900/1500	5.77 (146)	5.61 (143)	6.42 (163)	7.00 (178)	2.18 (55.4)	2.18 (55.4)		15.65 (7.1)
	2500	6.22 (158)	6.06 (154)	6.88 (174.7)	8.00 (203)	2.18 (55.4)	2.24 (56.9)		26.01 (11.8)
2 (DN 50)	150	5.22 (132)	5.06 (129)	5.85 (148.7)	6.00 (152)	2.00 (50.6)	2.18 (55.4)	13.01 (5.9)	
	300/600 ^①	5.47 (139)	5.31 (135)	6.12 (155.5)	6.50 (165)	2.18 (55.4)	2.24 (56.9)	13.45 (6.1)	
	900/1500 ^①	6.48 (165)	6.34 (161)	7.17 (182)	8.50 (216)	2.18 (55.4)	2.24 (56.9)	23.15 (10.5)	
	2500 ^①	6.85 (174)	6.70 (170)	7.54 (191.5)	9.25 (235)	2.61 (66.2)	2.67 (67.7)	34.61 (15.7)	

① For DBB sizes DN50 Class 300 and up, the secondary block and vent valves are oriented 45 degrees from the primary block valve.

Process Monoflanges

Dimensions, Integral Screwed-Bonnet Assemblies (MS03 Series)

Dimensions are for reference only and are subject to change.

For additional flange dimensions, see page 5.

MS03 Series (Integral Screwed-Bonnet) Bore Sizes

All bores 0.2 in. (5 mm)

For DBB sizes DN50 Class 300 and up, the secondary block and vent valves are oriented 45 degrees from the primary block valve.

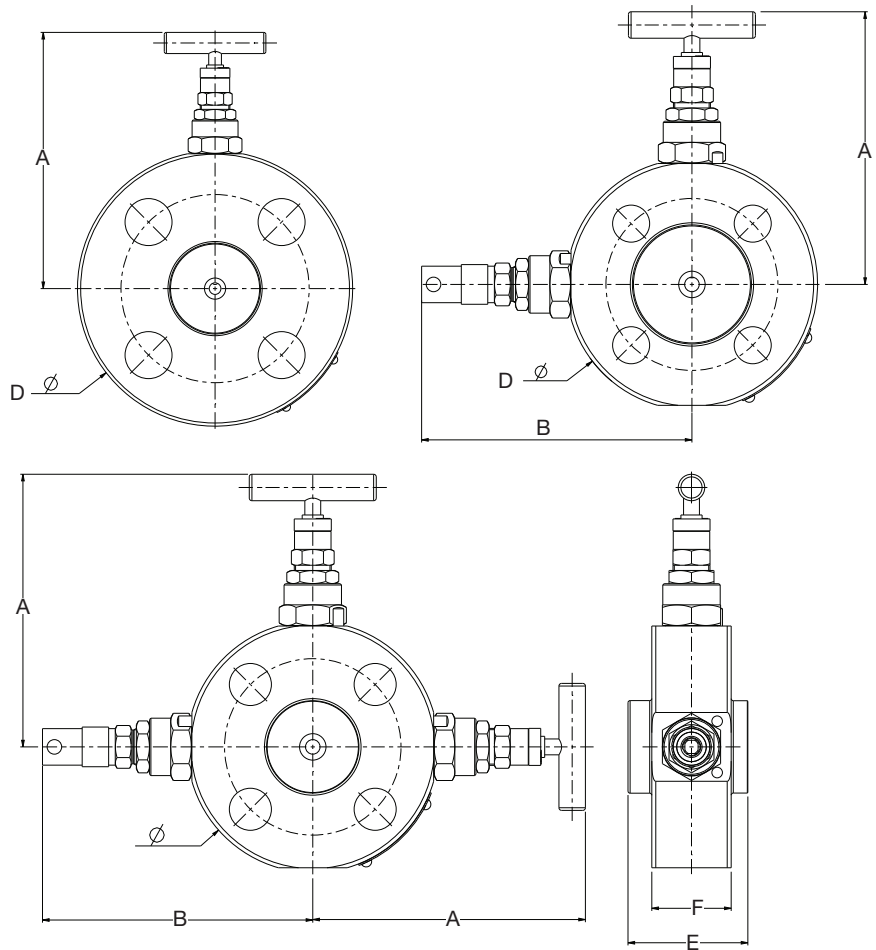

MS03 Monoflange		Dimensions, in. (mm)						
Flange Size in.	Class	A	B	∅ D	E for RF	E for RJ	F	Weight lb (kg)
1/2 (DN 15)	150	3.9 (99.9)	3.70 (96.0)	3.50 (88.9)	1.60 (40.6)	-	1.20 (30.0)	3.31 (1.5)
	300/600	4.10 (103)	3.90 (99.3)	3.75 (95.2)	1.80 (45.3)	1.70 (44.5)	1.20 (30.0)	3.75 (1.7)
	900/1500	4.60 (116)	4.40 (112)	4.75 (121)	1.80 (45.3)	1.80 (45.3)	1.20 (30.0)	5.51 (2.5)
	2500	4.80 (123)	4.70 (119)	5.25 (133)	1.80 (45.4)	1.80 (45.4)	1.20 (30.0)	7.50 (3.4)
3/4 (DN 20)	150	4.10 (105)	3.90 (101)	3.87 (98.4)	1.60 (40.6)	-	1.20 (30.0)	4.41 (2.0)
	300/600	4.50 (115)	4.40 (111)	4.62 (118)	1.80 (45.4)	1.80 (45.4)	1.20 (30.0)	5.51 (2.5)
	900/1500	4.80 (121)	4.60 (117)	5.12 (130)	1.80 (45.4)	1.80 (45.4)	1.20 (30.0)	6.61 (3.0)
	2500	4.90 (126)	4.80 (122)	5.50 (140)	1.80 (47.1)	1.80 (47.1)	1.25 (31.7)	7.72 (3.5)
1 (DN 25)	150	4.30 (110)	4.20 (106)	4.25 (108)	1.60 (40.6)	1.80 (45.3)	1.20 (30.0)	5.29 (2.4)
	300/600	4.60 (118)	4.50 (114)	4.87 (124)	1.80 (45.4)	1.80 (45.3)	1.20 (30.0)	6.61 (3.0)
	900/1500	5.10 (131)	5.00 (127)	5.87 (149)	1.80 (45.4)	1.80 (45.4)	1.20 (30.0)	9.04 (4.1)
	2500	5.30 (135)	5.20 (132)	6.25 (159)	2.00 (50.4)	2.00 (50.4)	1.40 (35.0)	11.90 (5.4)
1 1/2 (DN 40)	150	4.70 (120)	4.60 (116)	5.00 (127)	1.60 (40.6)	1.80 (45.4)	1.20 (30.0)	6.61 (3.0)
	300/600	5.30 (134)	5.10 (130)	6.12 (156)	1.60 (40.6)	1.80 (45.4)	1.20 (30.0)	12.13 (5.5)
	900/1500	5.80 (146)	5.60 (143)	7.00 (178)	1.90 (47.2)	1.90 (47.2)	1.25 (31.8)	13.23 (6.0)
	2500	6.20 (158)	6.10 (154)	8.00 (203)	2.30 (60.1)	2.40 (61.6)	1.76 (44.7)	23.37 (10.6)
2 (DN 50)	150	5.20 (132)	5.10 (129)	6.00 (152)	1.60 (40.6)	1.80 (45.4)	1.20 (30.0)	9.48 (4.3)
	300/600 ^①	5.50 (139)	5.30 (135)	6.50 (165)	1.80 (45.4)	1.85 (46.9)	1.20 (30.0)	11.24 (5.1)
	900/1500 ^①	6.50 (165)	6.30 (161)	8.50 (216)	2.10 (53.5)	2.20 (55.0)	1.50 (38.1)	22.71 (10.3)
	2500 ^①	6.85 (174)	6.70 (170)	9.25 (235)	2.60 (66.2)	2.70 (67.7)	2.00 (50.8)	35.27 (16.0)

① For DBB sizes DN50 Class 300 and up, the secondary block and vent valves are oriented 45 degrees from the primary block valve.

Process Monoflanges

Ordering Information

Build a process monoflange ordering number by combining the designators as shown below.

A B C D E F G H J K L
MS 03 03 SA A 63E 15 B1 C A A FE

A Series

- 02** = OS&Y bolted-bonnet needle valve (primary block)
(available with S17400 SS and Graphite needle seals only, select **B** Needle, Seals)
- 03** = Integral screwed-bonnet needle valve (primary block)

B Configuration

- 01** = Block
- 02** = Block and bleed
- 03** = Double block and bleed
- 04** = Block and bleed, dual outlet

C Materials

Standard

- SA** = 316 SS body and bonnet
- CA** = Carbon steel body, 316 SS bonnet
- DA** = Duplex SS body and bonnet

Available

- DB** = Super duplex SS
- DE** = Super duplex SS (NORSOK)
- NA** = Alloy 400
- NB** = Alloy 625
- NC** = Alloy 825
- SB** = 6 Moly Alloy
- ND** = Alloy C-276

D Needle, Seals

- A** = S17400 SS, PTFE
- B** = S17400 SS, Graphite
- E** = Needle same as body material, PTFE seals
- F** = Needle same as body material, Graphite seals
- J** = 625, PTFE
- K** = 625, Graphite
- L** = C-276, PTFE
- P** = C-276, Graphite
- Q** = 254, PTFE
- R** = 254, Graphite
- S** = M400, PTFE
- T** = M400, Graphite

E Pressure Class

ASME

- 1** = 150
- 3** = 300/600
- 5** = 900/1500
- 6** = 2500

DIN/EN

- 40E** = PN40
- 63E** = PN63
- 100E** = PN100
- 160E** = PN160
- 250E** = PN250
- 320E** = PN320

F Process Connection Size

ASME

- A** = 1/2 in. (DN 15)
- B** = 3/4 in. (DN 20)
- C** = 1 in. (DN 25)
- D** = 1 1/2 in. (DN 40)
- E** = 2 in. (DN 50)

DIN/EN

- 15** = DN 15
- 25** = DN 25
- 50** = DN 50

G Process Connection

- 1** = Flange—RF smooth
(3.2 to 6.3 µm)
- 2** = Flange—RF serrated
(6.3 to 12.5 µm)
- 3** = Flange—RTJ (not available with ASME class 150 1/2 in. and 3/4 in. [DN 15 and DN 20] process connection sizes)

B1 or B2 = EN Raised Face

H Outlet Connection

- 2** = Monoflange wafer (thru holes)
- A** = 1/4 in. female NPT
- C** = 1/2 in. female NPT
- F** = G 1/4[Ⓛ]
- G** = G 1/2[Ⓛ]

[Ⓛ] Compatible with Swagelok RS and RP fittings

J Bleed Connection

- A** = 1/4 in. female NPT
- C** = 1/2 in. female NPT
- F** = G 1/4
- G** = G 1/2
- = None (required for configuration **01**)

K Handles

Configuration 01

- B** = Block, bar

Configuration 02

- A** = Block, bar;
bleed, antitamper[Ⓛ]
- B** = Block and bleed, bar

Configuration 03

- A** = All block, bar;
bleed, antitamper[Ⓛ]
- B** = All handles, bar

[Ⓛ] Antitamper key sold separately, see page 30.

L Low Emissions Options

- FE** = Low emissions certification per ISO 15848-1
- F2** = ISO-15848-2 production test

Available Options

Option	Description	Designator
SilcoNert Coating ^①	Chemically inert coating	12457
Positive Material Identification (PMI)	PM2 testing per Swagelok SCS-00209	PM2
Dye Penetrant	Testing and test report available upon request	43100

^① All MS series valves include a fixed identification tag.
Not applicable to Nickel based Alloys, Monel, or Duplex/SuperDuplex materials.

Accessories

Antitamper Key

- Fits all Swagelok antitamper handles
- Order separately

Ordering number: **S004468** (VB04 series)
8164006 (VS03, VS04, MS series)



Flange Adapters

Refer to Swagelok *Flange Adapters* catalog, [MS-02-200](#), for additional information.



Pressure Gauges

Refer to Swagelok *Pressure Gauges, Industrial and Process—PGI Series* catalog, [MS-02-170](#), for additional information.



Tubing

Swagelok can provide a variety of stainless steel tubing in fractional, metric, and Imperial sizes. For more information, contact your authorized Swagelok representative.



Tube Fittings and Adapter Fittings

Refer to Swagelok *Gaugeable Tube Fittings and Adapter Fittings* catalog, [MS-01-140](#), for additional information.



Warranty Information

Swagelok products are backed by The Swagelok Limited Lifetime Warranty. For a copy, visit [swagelok.com](#) or contact your authorized Swagelok representative.



Sample Probe Module

Refer to Swagelok *Sample Probe Module, Application Guide* catalog, [MS-02-425](#), for additional information.

Ball Valves

Refer to Swagelok *Ball Valves, General Purpose and Special Application—60 Series* catalog, [MS-01-146](#), for additional information.

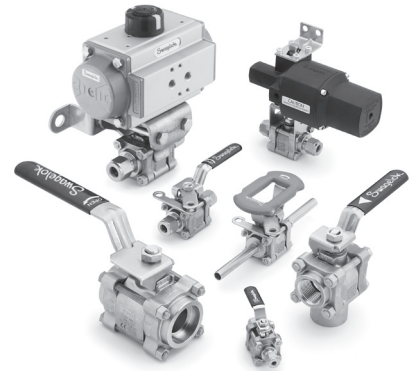

High-Pressure Needle Valves

Refer to Swagelok *Forged-Body Needle Valves, 10 000 psig (689 bar)—F10 Series* catalog, [MS-02-215](#), for additional information.



Safe Product Selection

When selecting a product, the total system design must be considered to ensure safe, trouble-free performance. Function, material compatibility, adequate ratings, proper installation, operation, and maintenance are the responsibilities of the system designer and user.

⚠ WARNING

Do not mix/interchange Swagelok products or components not governed by industrial design standards, including Swagelok tube fitting end connections, with those of other manufacturers.